

18" RCP HEADWALL

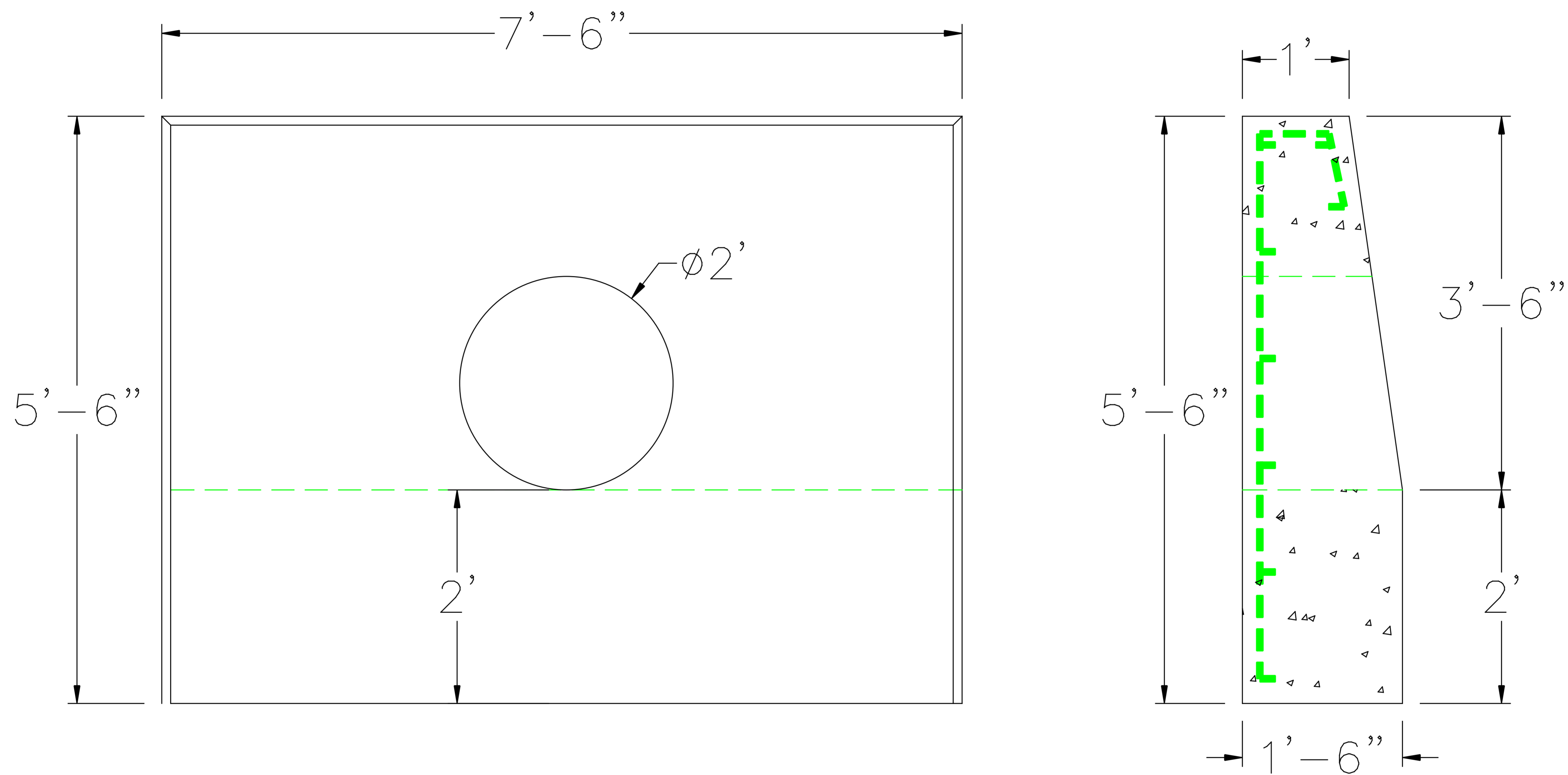

DESIGN NOTES:

1. CONCRETE 5,000 PSI @ 28 DAYS
2. REINFORCEMENT ASTM A-615 GRADE 60, 2" MIN. COVER #5 REBAR 12" O.C. 1 1/2" CLEARANCE
3. CONFORMS TO MHD STANDARD Dwg.206.4 - 1 1/2 : 1 SLOPE
4. WEIGHT = 7,000 lbs



SCITUATE RAY PRECAST
 120 CLAY PIT ROAD
 MARSHFIELD, MA 02050
 PHONE # 1-800-440-0009
 FAX # 781-837-4320

| | | | |
|-------------|-------------------|-------------|-------------|
| CONTRACTOR: | | JOB NAME: | |
| DATE: | DRAWING: SRP-HW18 | DRAWING BY: | C. J. SCOTT |