

6-OUTLET DISTRIBUTION BOX (2' X 2' H-20)

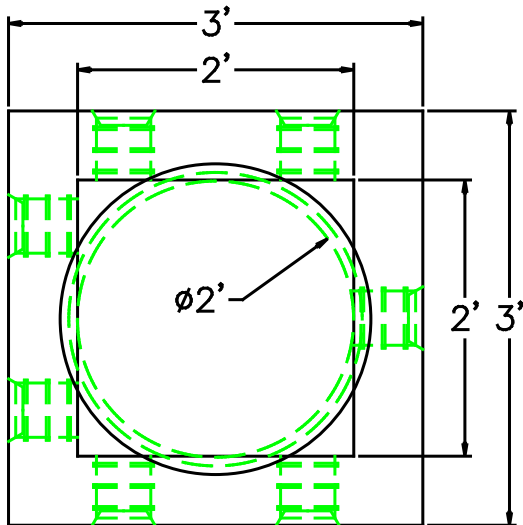

DESIGN NOTES:

1. CONCRETE 4,000 PSI @ 28 DAYS
2. KNOCK-OUT OPENINGS FOR 4" PVC
3. REINFORCING ASTM A-615, GRADE-60
4. BUTYL SEALANT AVAILABLE
5. DESIGN LOADING AASHTO HS-20

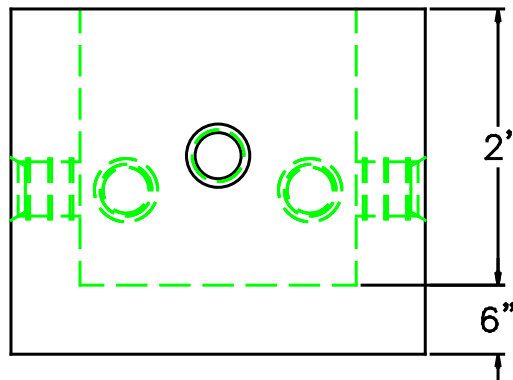
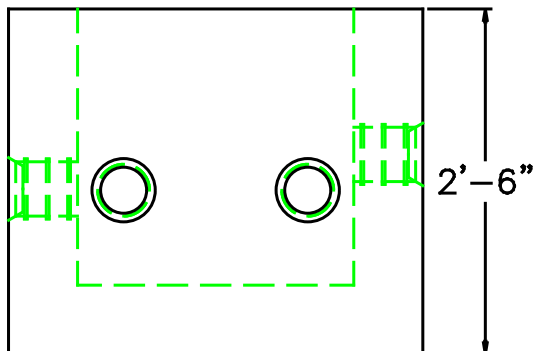
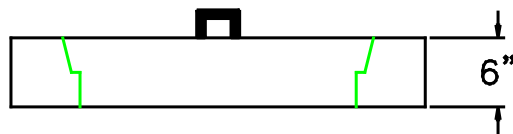
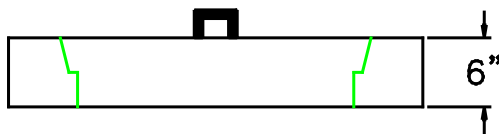

SCITUATE RAY PRECAST
 120 CLAY PIT ROAD
 MARSHFIELD, MA 02050
 PHONE # 1-800-440-0009
 FAX # 781-837-4320

CONTRACTOR:

JOB NAME:

DATE:

DRAWING: DB-9-20

DRAWING BY: C.J. SCOTT

