

# 5' DIA GAS TRAP W/ 6" INLET

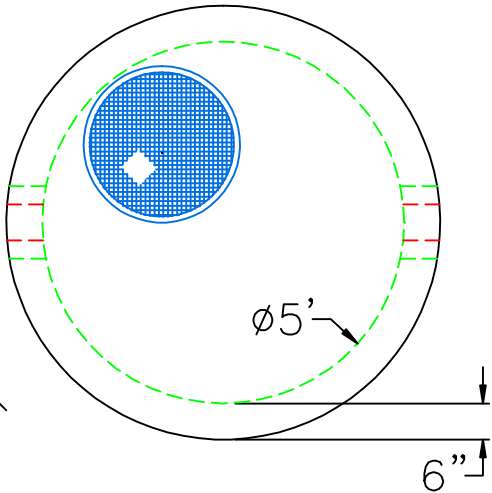
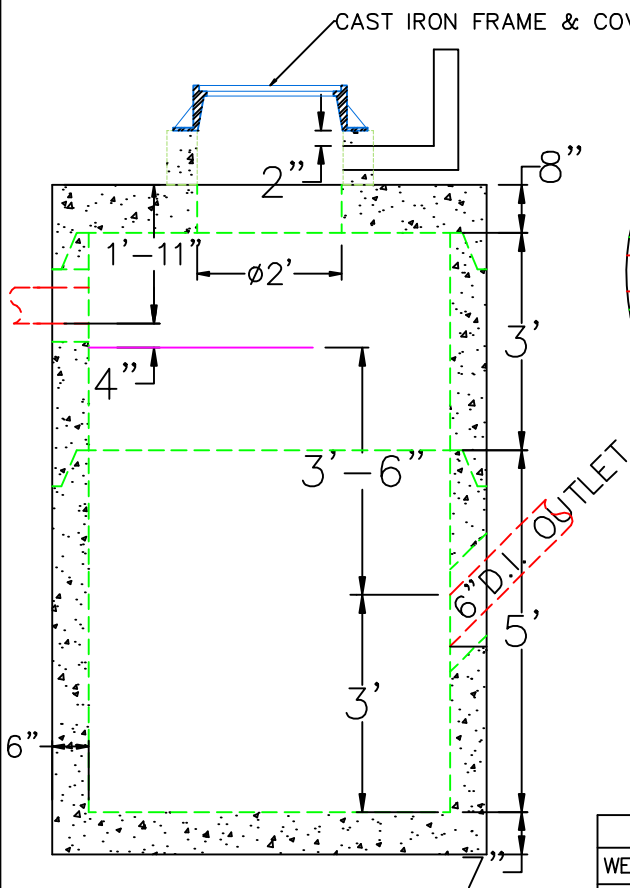

	FLOOR	VERT. FT	FLAT TOP
WEIGHT	1,530 lbs.	1,300 lbs.	2,840 lbs.
VOLUME		146.8 gal.	

## DESIGN NOTES:

1. MANUFACTURED TO MEET OR EXCEED: ASTM C-478 & AASHTO M 199 SPECS.
2. CONCRETE = 4,000 PSI. MINIMUM CEMENT PER ASTM C-478 (6.1)
3. REINFORCED STEEL COMFORMS TO LATEST ASTM A 185 SPECIFICATIONS. 0.15 SQ. IN / LINEAL FT. AND 0.15 SQ. IN (BOTH WAYS) BASE BOTTOM
4. STEEL REINFORCEMENT TO MEET OR EXCEED AASHTO HS-20 LOADING
5. MANHOLE STEPS MEET LATEST OSHA REGULATION 29 CFR1910.27, SECTION 16 OF ASTM SPECIFICATION C478 AND SECTION 10 OF ASTM SPECIFICATION C497
6. BUTYL RUBBER JOINT SEALANT PER ASTM C-990 & ASHTO M-198
7. ONE POUR MONOLITHIC BASE
8. WEIGHT PER VERTICAL FOOT=1500 lbs., FLOOR=2470 lbs., FLAT TOP=3250 lbs.
9. COMMONWEALTH OF MASSACHUSETTS BOARD OF EXAMINERS OF PLUMBERS AND GASFITTERS GASOLINE, OIL AND SAND SEPARATOR DESIGN
10. EXTERIOR TO BE COATED WITH SCITUATE COMPANIES STANDARD DAMPROOFING

A1	COMPRESSION GASKET (CAST IN)	
A2	FLEXIBLE SLEEVE	
A3	MORTAR BY CONTRACTOR	
B	BUTYL RUBBER SECTION JOINT	
C	POLYPROPYLENE MANHOLE STEPS	



SCITUATE RAY PRECAST  
 120 CLAY PIT ROAD  
 MARSHFIELD, MA 02050  
 PHONE # 1-800-440-0009  
 FAX # 781-837-4320

CONTRACTOR:		JOB NAME:	
DATE:	DRAWING: SRP-GT5	DRAWING BY:	C. J. SCOTT