

14 OUTLET DISTRIBUTION BOX

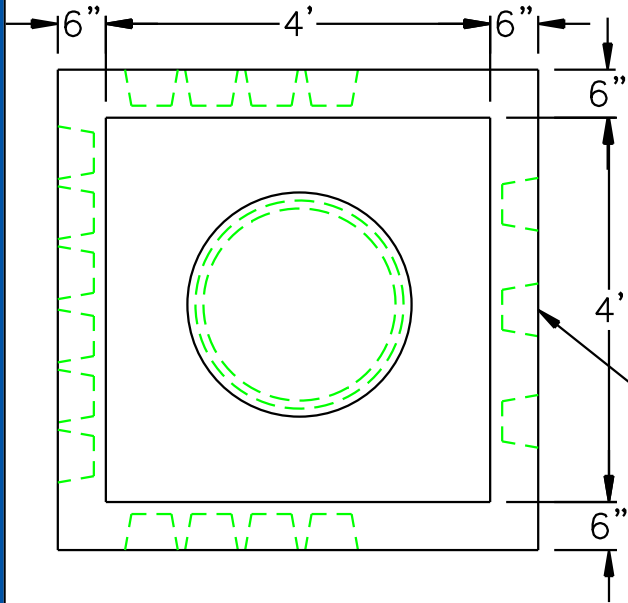

DESIGN NOTES:

1. CONCRETE 5,000 PSI @ 28 DAYS
2. REINFORCEMENT ASTM A-615 GRADE 60, 1" MIN. COVER
3. DESIGNED FOR H-20 LOADING

(3) $\phi 7\frac{1}{2}$ " INLET KNOCKOUTS

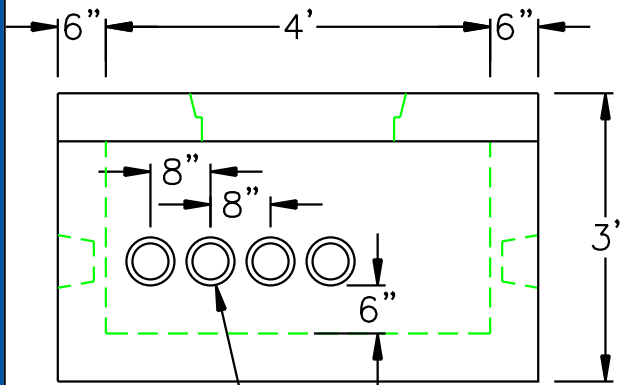

(14) $\phi 5$ " KNOCKOUTS

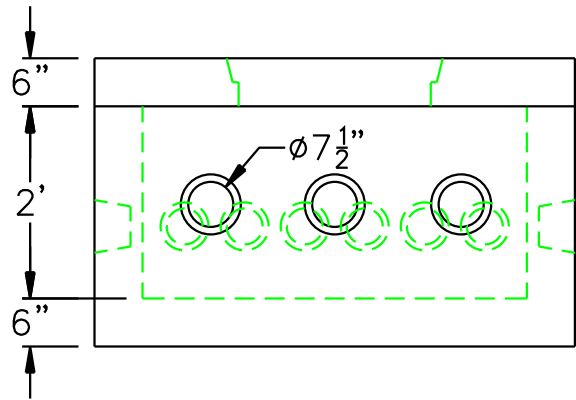

SCITUATE RAY PRECAST
 120 CLAY PIT ROAD
 MARSHFIELD, MA 02050
 PHONE # 1-800-440-0009
 FAX # 781-837-4320

| | | | |
|-------------|--------------------|-------------|-------------|
| CONTRACTOR: | | JOB NAME: | |
| DATE: | DRAWING: SRP-EMH44 | DRAWING BY: | C. J. SCOTT |